



## ***Driver Unit mk II***

*Driver Unit for Electrostatic, Dynamic and Planar Headphones*

### *Owner's Manual*



This product contains high voltage circuitry. To avoid dangerous electric shock, do not disassemble or modify the unit.

RISK OF ELECTRIC SHOCK, DO NOT OPEN!



[www.soltanusacoustics.com](http://www.soltanusacoustics.com)



## Safety information (Please read first)

### • Prior to use – About WARNING/CAUTION marks

Various WARNING and CAUTION marks are used in this manual for safe usage of the unit. The possible danger or trouble caused by disregarding the marks and mishandling the unit are classified as follows. Please read the manual with these WARNING/CAUTION marks in mind.

 <b>WARNING</b>	Disregarding this mark and mishandling the unit could result in serious injury or death.
 <b>CAUTION</b>	Disregarding and mishandling this mark might result in injury or physical damage.



This mark urges user to take precaution (warning included). Left example shows “electric shock” caution.



This mark tells prohibited actions. Left example shows “disassembly-forbidden”.



This mark tells actions you must take without fail. Left example shows “pull out plug from wall socket”.



### WARNING

-  • Do not pull out or insert mains or headphone plug with wet hand to avoid electric shock.
- Do not use any other mains voltage than indicated.
- Do not bend, twist or pull the power cable by force, nor modify it.
- Do not cover the heat dissipation holes on side panels.
- Do not put metal, liquid or other object into the unit.
- Do not touch the output terminal for headphone



### WARNING



- In case smoke comes out or unusual smell or sound is perceived, stop using and shut off the power immediately, and then pull out mains plug from wall socket. Further using the unit involves the risk of a fire or electric shock, etc. It is dangerous for a customer to repair the unit. Please contact your audio shop or the service division of our company.



- Do not remove the bottom plate or the top cover nor any of the covers.
- Do not attempt disassembly or modification.



### CAUTION



Do not put this product on the following places. Otherwise, it may cause injury or unit failure.

- Places sensitive to vibration or shock, slanted or exposed to direct sunlight.
- Places with much moisture, humidity and dust.
- Places where temperature differs intensely or near heating appliance (stove, heater, etc.).
- Do not put headphone or any other object on the unit. It may cover the venting holes and cause heat generation resulting in unit failure.



- Dropping or giving a shock should be avoided. It becomes the cause of failure.
- Don't raise volume too much. Listening with large volume could lead to hearing damage. Listening with moderate volume is recommended both for your ear and for the unit.



Thank you for purchasing the **soltanus acoustics driver unit mk II** designed for use with electrostatic, dynamic and planar headphones.

Please read this manual thoroughly to ensure safe operation and to maximize the performance of the unit for years of optimal listening. Be sure to retain this manual, along with the warranty card, for future reference.

## Features

The **Driver Unit MK II** was developed to deliver the emotional intensity of music in the most technically efficient way possible, while maintaining the same compact size as the previous **Soltanus Acoustics Driver Unit MK I**.

Considering the technical expertise in amplifier design and the high standards of audiophile requirements, the voltage gain for electrostatic headphones has been achieved using carefully engineered, hand-wound output audio transformers with a wide frequency bandwidth and exceptional quality.

The built-in audio transformers have been designed to maintain a high impedance across the entire audio band, ensuring easy drivability with a variety of amplifiers. This design preserves high voltage gain without compromising sonic quality, even beyond the audible frequency range.

The unusually large iron core cross-section prevents saturation, even at subsonic frequencies, with output levels up to 2,000 Vpp. At the same time, it maintains the winding capacitance at the lowest possible values.

The **additional Impedance Switch** on the **Driver Unit MK II** allows you to adjust its input impedance to higher values, ensuring compatibility with amplifiers that have **high output impedance** or use **low- or zero-feedback topologies**.

The unit can be used in a vertical position as a headphone stand, or in a horizontal position, functioning like a conventional amplifier.

The **Driver Unit MK II** is equipped with two switchable inputs: one featuring speaker binding posts for loudspeaker amplifiers, and one balanced XLR 4-pin input for headphone amplifiers. These two inputs are fully electrically isolated, allowing you to connect two amplifiers simultaneously, including amplifiers with bridged outputs and floating (non-grounded) negative poles.

The **Driver Unit MK II** is also equipped with two types of headphone outputs: a 5-pin PRO-type socket for electrostatic headphones, and a balanced 4-pin XLR output for dynamic or planar magnetic headphones. Both outputs are active simultaneously.

The balanced 4-pin XLR output features a **sensitivity switch** on the back panel with three selectable positions, optimized for headphones with sensitivities of **80+ dB, 90+ dB, and 100+ dB**.

The 580V DC bias is realized with simplest low noise voltage multiplier.

The **Driver Unit MK II** is also equipped with overvoltage protection, which is designed to activate only when the input voltage exceeds 14 Vrms.

The **Driver Unit MK II** features a non-magnetic, 3mm thick aluminum chassis, and utilizes only carefully selected electronic components, free from age-related deterioration, chosen for both their sonic quality and performance.

## Precautions for use



There are high-voltage sections inside the unit. Do not remove the top cover or bottom plates, and avoid using the unit in humid or dusty environments.

Do not open the unit unless you are a qualified technician, as there are dangerous high voltages inside that pose a risk of electric shock.

This product operates with high voltages, and attempting to dismantle or modify the unit in any way is extremely dangerous. Under no circumstances should such actions be attempted.

Exercise caution with the **LEVEL CONTROL** of your amplifier, especially if using a loudspeaker amplifier with high output capabilities. Do not apply input voltages greater than 14 Vrms to the **Driver Unit MK II**, as doing so may cause damage to both the driver unit and your headphones.

Since the **Driver Unit MK II** can produce high volumes without distortion, please be mindful of the volume levels to avoid damaging your hearing or overdriving your headphones.

When plugging in or unplugging the electrostatic cable, always turn off the **Driver Unit MK II** and set the volume of your amplifier to zero to avoid the risk of electric shock.



Do not leave the unit turned on when not in use.  
Protect it from direct sunlight and avoid exposing it to ambient temperatures above 35°C (95°F).

## Switches and functions (Front panel)

1. **Power Switch:** The "0" position is OFF, and the "1" position is ON. Before connecting, ensure that the "Power Switch" is in the OFF position. The **Driver Unit MK II** can be ordered with the power switch positioned either vertically or horizontally.
2. **Power Indicator LED:** The power indicator LED is available in red, blue, green, white, or yellow colors, depending on your preference.
3. **Balanced 4-Pin XLR Output:** For use with dynamic or planar headphones.
4. **5-Pin PRO-Type Electrostatic Headphone Socket:** Insert the 5-pin type headphone plug into this socket.

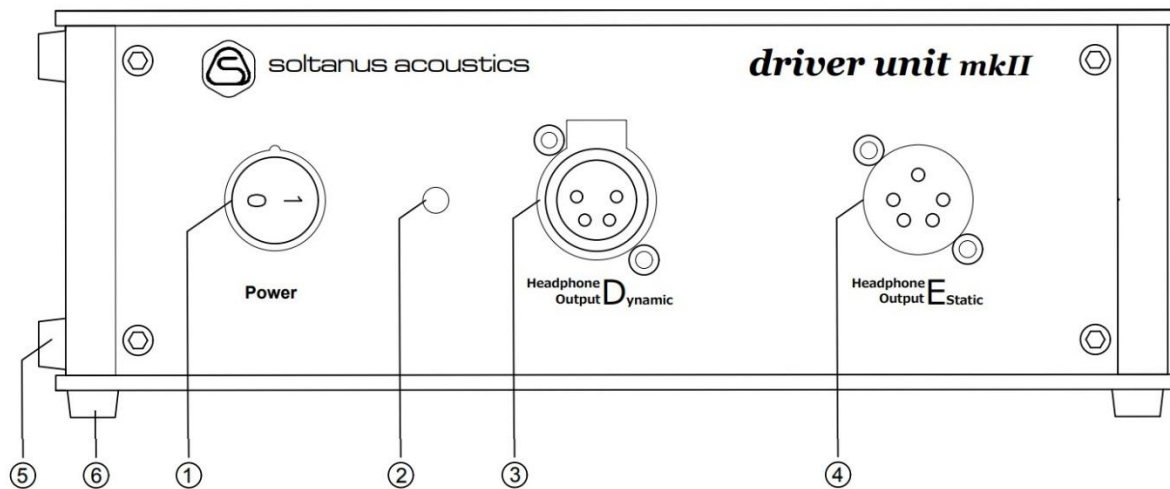

### When power on and off:

- It is recommended to turn OFF the power when plugging in or unplugging the electrostatic headphone cable.
- Keep the unit in the OFF position when not in use.
- Turn the unit ON before switching on the driving amplifier.
- Turn the unit ON before using electrostatic headphones.
- The dynamic and planar outputs are functional even when the power is in the OFF position.

5. **Legs for Vertical Use:** Designed for stable placement when the unit is used in a vertical position.
6. **Optional Legs for Horizontal Use:** These legs are available for stable placement when the unit is used in a horizontal position.



## Terminals and functions (Rear panel)

5. **Legs for Vertical Use:** Designed for stable placement when the unit is used in a vertical position.
6. **Optional Legs for Horizontal Use:** These legs are available for placement when the unit is used in a horizontal position.
7. **Balanced XLR 4-Pin Input Terminal:** For use with headphone amplifiers.
8. **Input for Speaker Amplifier with Binding Posts:** Compatible with both amplifiers featuring a grounded negative pole or amplifiers with floating negative poles (balanced or bridged amplifiers).
9. **Input Switch:** For selecting between:
  - **Balanced XLR 4-pin Input.**
  - **Input with Speaker Binding Posts.**
10. **Impedance Switch :** This switch only affects the electrostatic transformer circuit and has no effect on the dynamic-planar output, unless your amplifier's output impedance is too high.
  - **Low Impedance:** The impedance of the audio transformers is 30 Ohms at 20 Hz, with a step-up ratio of 1:50. This position is recommended for headphone amplifiers with lower output impedance and speaker amplifiers with lower output power.
  - **High Impedance:** In this position, the impedance of the audio transformers is 150 Ohms at 20 Hz, with a step-up ratio of 1:25. This setting is recommended for amplifiers with high output impedances (low or no feedback) or amplifiers with higher output voltages.

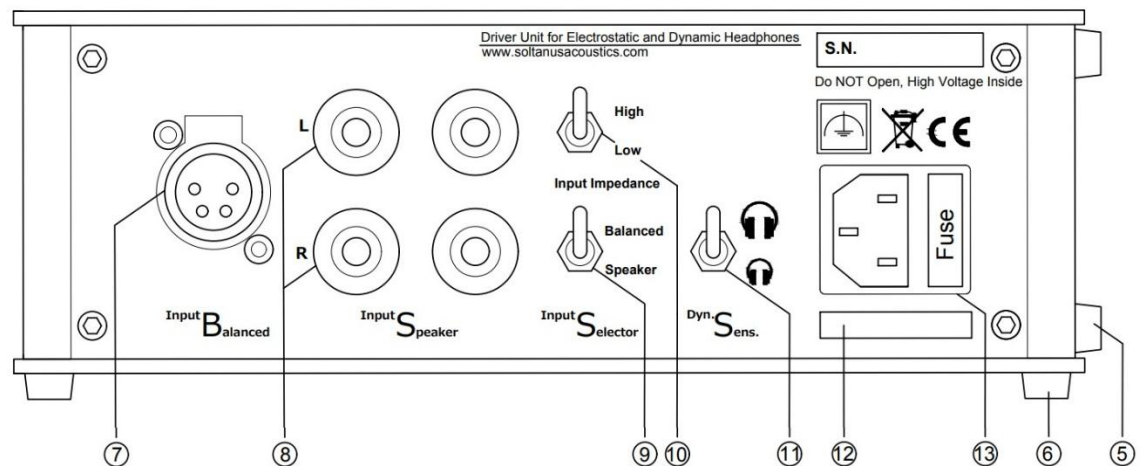

11. **Headphone Sensitivity Switch:** Controls the output level for dynamic or planar headphones in three steps.
  - **Right Position (MID Sensitivity):** In the horizontal position (down in the vertical position), indicated by the "little" headphone symbol, this setting is for headphones with a sensitivity range of 90–100 dB. The maximum output voltage in this position is 2.6 Vrms.
  - **Left Position (LOW Sensitivity):** In the horizontal position (up in the vertical position), indicated by the "big" headphone symbol, this setting is for headphones with a sensitivity range of 80–90 dB. The maximum output voltage in this position is 10 Vrms.
  - **Center Position (HIGH Sensitivity):** This setting is for headphones with a sensitivity of 100 dB and above. The maximum output voltage in this position is 1.5 Vrms.

Please be cautious when adjusting the position of this switch to avoid damaging your headphones. Select the position where any hum in your headphones disappears, depending on your amplifier's noise floor. A slight hum may be audible if the output level is too high for your headphones (e.g., when using highly sensitive headphones), and this can also overload your headphones. Note that this switch only affects the electrostatic output if your amplifier's output impedance is too high..

12. **Voltage and Fuse Indication:** Set according to the voltage requirements of your country.
13. **AC Inlet with Fuse:** Insert the power cable here.



## Specifications

- Frequency response: the same as your amplifier's response for dynamic output and 4Hz - 60kHz +0, -3dB for electrostatic output.
- Rated input level: 14 Vrms max.
- Gain Low impedance: 34 dB (x 50) for electrostatic outputs.
- Gain High impedance: 28 dB (x 25) for electrostatic outputs.
- Gain Dynamic Output Low sens. Position: -1.6 dB
- Gain Dynamic Output Mid. sens. Position: -13 dB
- Gain Dynamic Output High sens. Position: -18 dB
- Harmonic distortion: 0.01% or less (1kHz)
- Low Input impedance: 30 Ω at 20 Hz
- High Input impedance: 150 Ω at 20 Hz
- Maximum electrostatic output voltage: 700Vrms (1974Vp-p) / 1kHz
- Maximum output voltages for dynamic or planar headphones: 10/2.6/1.5Vrms (28.2/7.3/4.2 Vp-p) / 1kHz
- Bias voltage: 580V DC
- Mains voltage: AC100V/ AC110-120V/AC230-240, 50/60Hz (depending on your country's voltage)
- Power consumption: 0.1 W/Max
- Required amplifier power: To reach 110 dB using electrostatic headphones with a sensitivity of 100 dB/100V, the required power is 1.2W (6 Vrms at 30 Ohms).
- Operating temperature: 0 to 35 degrees C (less than 90% humidity, non condensing)
- Dimension: 230 (W) x83 (H) x255 (D) mm (maximum protruding portion included in horizontal position)
- Weight: 4.3kg

Specifications and appearance are subject to change without notice as part of ongoing improvements.

This product is adjusted to the mains voltage according to the requirements of each country.

## Care and cleaning

- Pull the power cable from the wall socket and wipe it with a dry, soft cloth. If it is very dirty, first wipe off the dirt with a damp cloth, then finish by wiping it with a dry cloth.

## Troubleshooting

- Do not use benzine, thinner, or alcohol, as they may damage the paint, printing, or other surfaces. Before using a chemical dust cloth, check the instructions to ensure it is safe for use with audio equipment.

### Accessories

- Owner's manual.....1
- Warranty card.....1
- Optional legs for horizontal use.....4

### No Sound

- Is the plug of Power cable inserted into the wall socket ?
- Is the power switch on ?
- Does LED on the front panel light up ?
- Check that nothing is wrong with connecting cable.
- When connected to amplifier, check that the amplifier selector is set to connected source.

### Sound is distorted

- Is supply voltage in the stipulated range ?
- Is your amplifier capable of delivering 1.5-5 Watts at least
- Distortion will arise if the volume is turned up too high.

### Unbalanced L/R sound

- Are the input signals correct?
- Is the headphone cable properly connected?

### Hum noise is heard

- The grounding can be broken in power cable or in wall socket.
- Are the input terminals connected correctly ? If the ground side of cable is floated or has a poor contact, hum noise may occur.
- Is there any poor contact ?
- Is supply voltage within the stipulated range ?
- Due to the non-magnetic aluminum chassis, hum noise can be induced by nearby connected equipment. If equipment with large transformers, such as microwave ovens, is located near the **Driver Unit**, keep it away from the unit to prevent interference.

If you encounter any issues not described above, please contact your dealer, the authorized distributor in your country, or the manufacturer



## Warranty

---

Soltanus Acoustics products are covered by warranty from the original date of purchase (the "Warranty Period").

### What's covered

Soltanus Acoustics warrants to the original purchaser that the Soltanus product will be free from defects in manufacturing, parts, materials, and workmanship under normal use, in accordance with Soltanus Acoustics' published guidelines. These guidelines include, but are not limited to, information provided in technical specifications, user manuals, and service communications.

### What's not covered

This warranty does not cover defects resulting from improper or unreasonable use or maintenance; cosmetic damage, including but not limited to scratches, dents and broken parts; failure to follow operating instructions; accident; excess moisture; excess temperature; power surges; connections to improper voltage supply; unauthorized alteration or modification of original condition; damage caused by use with non-Soltanus Acoustics products; products purchased from unauthorized dealers; or defects incurred during transportation for which claims must be presented to the carrier.

### What we will do

At our sole discretion, and to the extent permitted by law, we will repair or replace (using new or refurbished Soltanus Acoustics products) any Soltanus Acoustics product that is covered under warranty for the period listed, starting from the date of the original retail purchase.

### What we will not do

We will not pay shipping, insurance or transportation charges, or any import fees, duties and taxes.

### Warranty eligibility statement

To be eligible for service under this warranty, you must include a valid bill of sale from an authorized Soltanus Acoustics retailer with the repair item(s). The bill of sale must detail the following information: retailer's name, original purchase date, proof of purchase, and serial number.

### Additional product information and limitations

Warranty Replacements Soltanus Acoustics strives to improve the performance of our products and reserves the right to make changes to designs, specifications, or materials at any time without prior notification. At its discretion, Soltanus Acoustics may choose to replace the product completely with a new or remanufactured unit. In the event of product obsolescence, a suitable replacement will be selected based on the features, intended use (as

determined by Soltanus Acoustics), and the retail price of the original product.

### Product

All warranty replacements are guaranteed for 90 days or until the end of the original Soltanus Acoustics product's warranty period, whichever is longer. Soltanus Acoustics does not offer advance replacements for Soltanus Acoustics products.

### Determining authority

Soltanus Acoustics will be the final determining authority for all potential warranty claims for service and/or replacement.

### Other conditions/rights

EXCEPT AS PROVIDED IN THIS WARRANTY AND TO THE MAXIMUM EXTENT PERMITTED BY LAW, SOLTANUS ACOUSTICS IS NOT RESPONSIBLE FOR DIRECT, SPECIAL, INCIDENTAL OR CONSEQUENTIAL DAMAGES RESULTING FROM ANY BREACH OF WARRANTY OR CONDITION, OR UNDER ANY OTHER LEGAL THEORY, INCLUDING BUT NOT LIMITED TO LOSS OF USE; LOSS OF REVENUE; LOSS OF ACTUAL OR ANTICIPATED PROFITS; LOSS OF GOODWILL; LOSS OF, DAMAGE TO, COMPROMISE OR CORRUPTION OF DATA; OR ANY INDIRECT OR CONSEQUENTIAL LOSS OR DAMAGE HOWSOEVER CAUSED INCLUDING THE REPLACEMENT OF EQUIPMENT AND PROPERTY. THE FOREGOING LIMITATION SHALL NOT APPLY TO DEATH OR PERSONAL INJURY CLAIMS, OR ANY STATUTORY LIABILITY FOR INTENTIONAL AND GROSS NEGLIGENT ACTS AND/OR OMISSIONS. SOME STATES IN THE USA OR OTHER COUNTRIES. DO NOT ALLOW THE EXCLUSION OR LIMITATION OF INCIDENTAL OR CONSEQUENTIAL DAMAGES, SO THE ABOVE LIMITATION OR EXCLUSION MAY NOT APPLY TO YOU. TO THE EXTENT PERMITTED BY LAW, THIS WARRANTY AND THE REMEDIES SET FORTH ARE EXCLUSIVE AND IN LIEU OF ALL OTHER WARRANTIES, REMEDIES AND CONDITIONS, WHETHER ORAL, WRITTEN, STATUTORY, EXPRESS OR IMPLIED. SOLTANUS ACOUSTICS DISCLAIMS ALL STATUTORY AND IMPLIED WARRANTIES, INCLUDING WITHOUT LIMITATION, WARRANTIES OF MERCHANTABILITY AND FITNESS FOR A PARTICULAR PURPOSE AND WARRANTIES AGAINST HIDDEN OR LATENT DEFECTS, TO THE EXTENT PERMITTED BY LAW. IN SO FAR AS SUCH WARRANTIES CANNOT BE DISCLAIMED, SOLTANUS ACOUSTICS LIMITS THE DURATION AND REMEDIES OF SUCH WARRANTIES TO THE DURATION OF THIS EXPRESS WARRANTY AND, AT SOLTANUS ACOUSTICS'S OPTION, THE REPAIR OR REPLACEMENT SERVICES DESCRIBED HEREIN. SOME STATES (INCLUDING COUNTRIES AND PROVINCES) DO NOT ALLOW LIMITATIONS ON HOW LONG AN IMPLIED WARRANTY (OR CONDITION) MAY LAST, SO THE LIMITATION DESCRIBED ABOVE MAY NOT APPLY TO YOU.

### Warranty period for Driver Unit MK II

Three years from the date of purchase.

